

New Features in *MEMS+*[®] 6.0

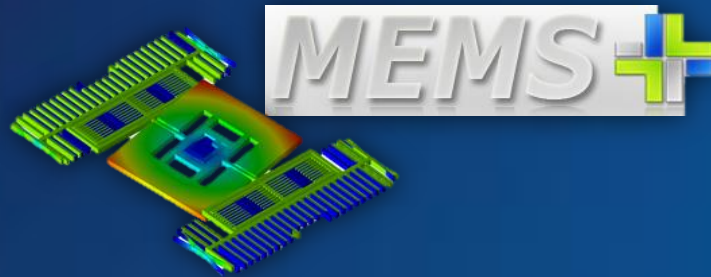

September 2015

Technology-defined Component Library – Reduces design errors

User-defined constraints on components

 Enables MEMS Process Design Kits (MPDKs)

Hierarchical design entry – Faster prototyping

Import Sub-schematics

Faster prototyping

New Library Components – More modeling flexibility

 Gap models

 Stack plates

 Fillet plates

Improved ROM Export – Simplified and more accurate

Performance and Ease-of-Use Improvements

- Improved package import visualization
- Faster schematic loading
- Zip export to package all files
- Expanded Matlab scripting interface
 - All *MEMS+* documents (mpd, proc etc.) can be handled
 - Improved scripting syntax

Technology-Defined Component Library

COVENTOR

MaterialDataBase

ProcessEditor

ComponentLibrary

Innovator

421
513 Simulator

Customize generic components to enforce process constraints and design rules

Export protected MPDK, which ensures the constraints are respected while creating 3D models

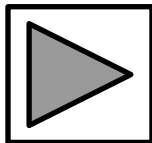

Component Library/
PDK Demo

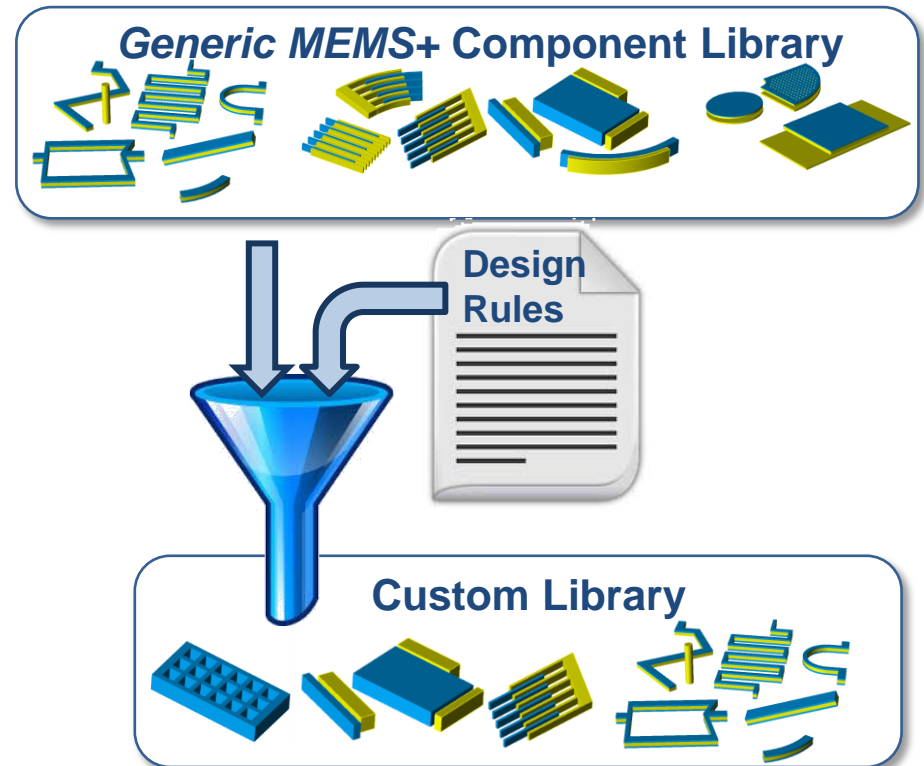

Use hierarchy to simplify design entry

- SubSchematics are just separate *MEMS+* schematics
- Changes in the SubSchematic propagate to the master schematic

Enables rapid testing of design/modeling permutations

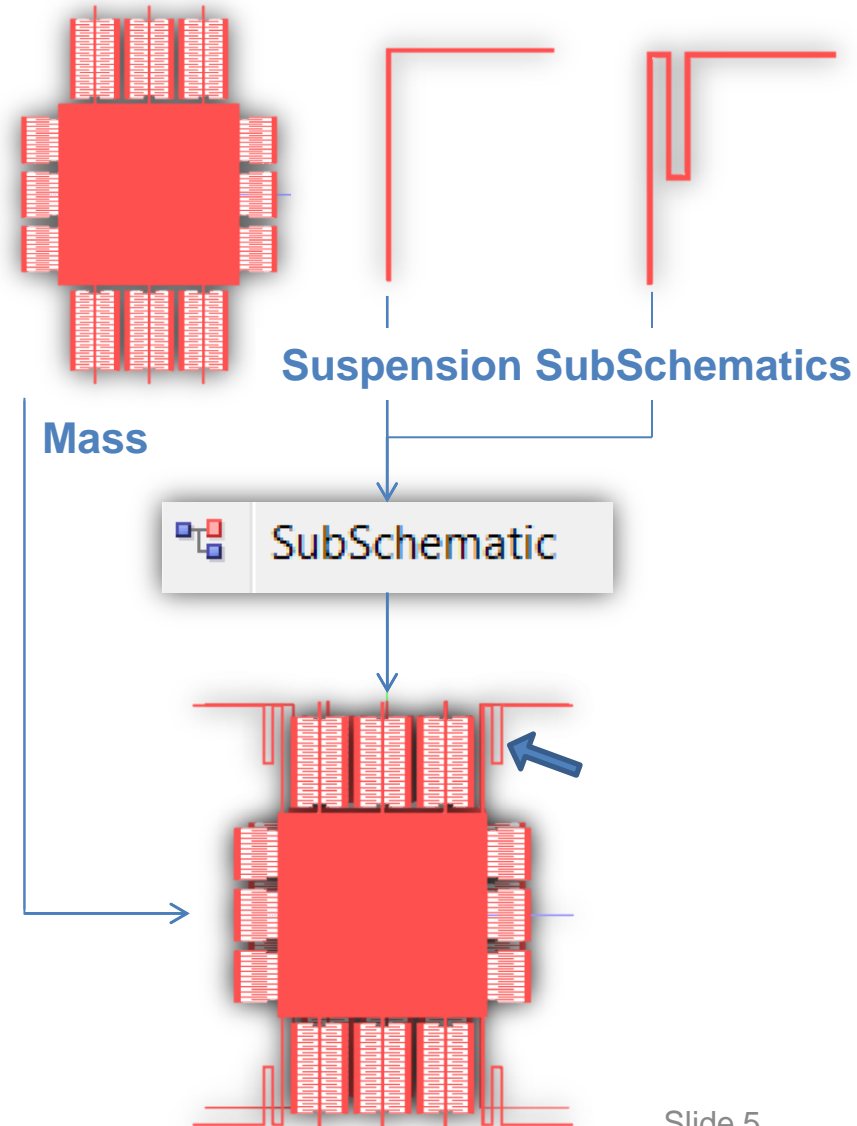

New Stack Components

COVENTOR

Model piezo-electric layers easily

- Create composite structures with layer-wise independent geometry
- Stacks do not require additional mechanical DoF's

MEMS+ 5
sectioned model
DoF = 203

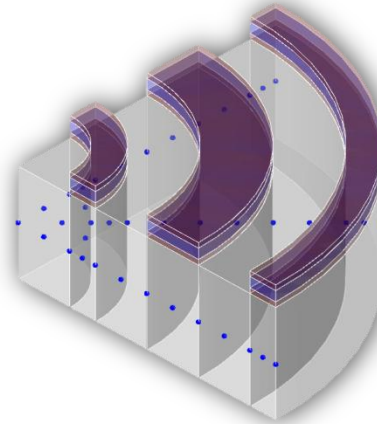

MEMS+ 6 with stack components
DoF = 46

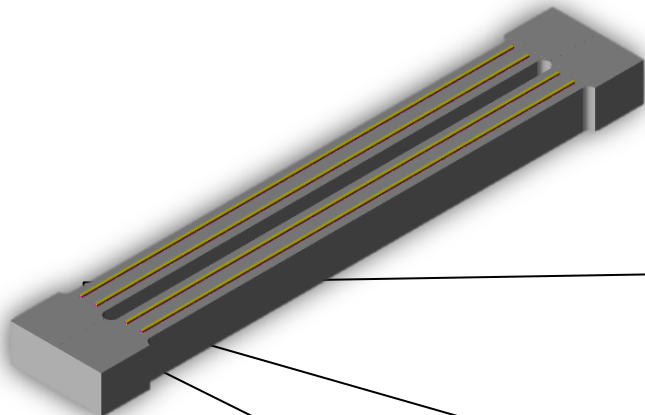
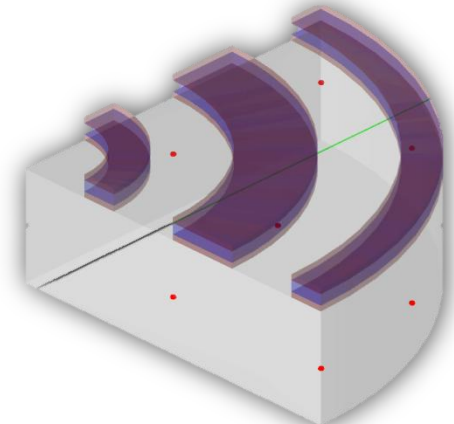

Reference: [US20120192649](https://patents.google.com/patent/US20120192649)

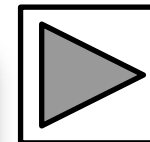
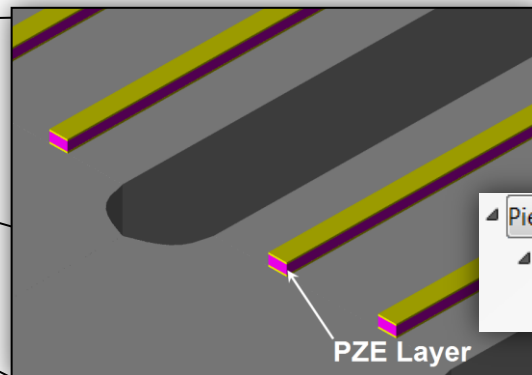

Stack Components Demo

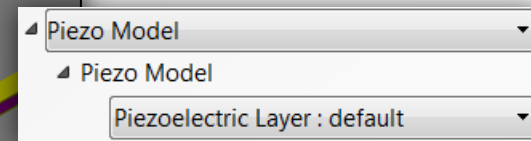

Gap Component

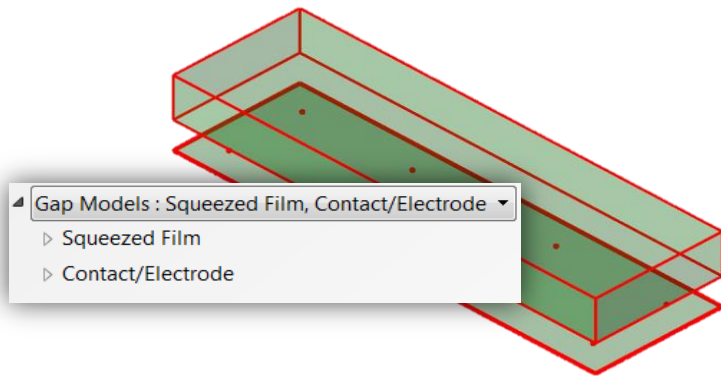

User selected physics in gap

- Squeezed film (SF) and/or Contact/Electrode
- Requirement of contact/electrode for SFD modeling is eliminated

Construct arbitrarily shaped gaps

Older SFD/Electrode models auto-updated

Corner Fillet

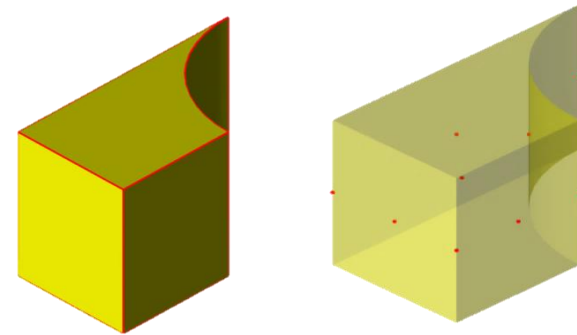

Flexible fillet components

- Concave and Convex forms
- Enables more realistic modeling

Enhanced Matlab Interface

Script everything! Create and manipulate **all MEMS+** documents including 3D-schematics via Matlab scripting

```
h = cov.memplus.Schematic('Gyroscope_prebuilt.mlib')
```

```
h.Variables.add('Variable')
h.Variables.Variable1.rename('PlateSizeX')
h.Variables.PlateSizeX.Properties.Value = 100;
h.Variables.add('Variable')
h.Variables.Variable1.rename('PlateSizeY')
h.Variables.PlateSizeY.Properties.Value = 100;
```

```
h.Components.add('Beam')
Beam1 = h.Components.Beam;
Beam1.Properties.Layers = {'poly'};
Beam1.Properties.Position.End1.x = -50;
Beam1.Properties.Position.End2.x = -150;
Beam1.Properties.Width = 5;
Beam1.Properties.FaceType.End1 = 'Fixed';
```

```
h.applyWizardActions
```

Open any MEMS+ document

ab Variables

Pressure	101325
T	273.15
PlateSizeX	100
PlateSizeY	100

Create variables

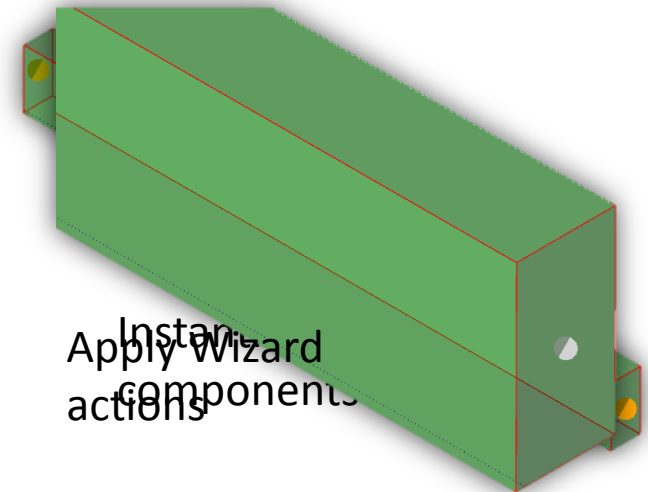

Scripting interface follows the same structural hierarchy as the Simulator Plug-in UI

Simulator Plug-in process flow

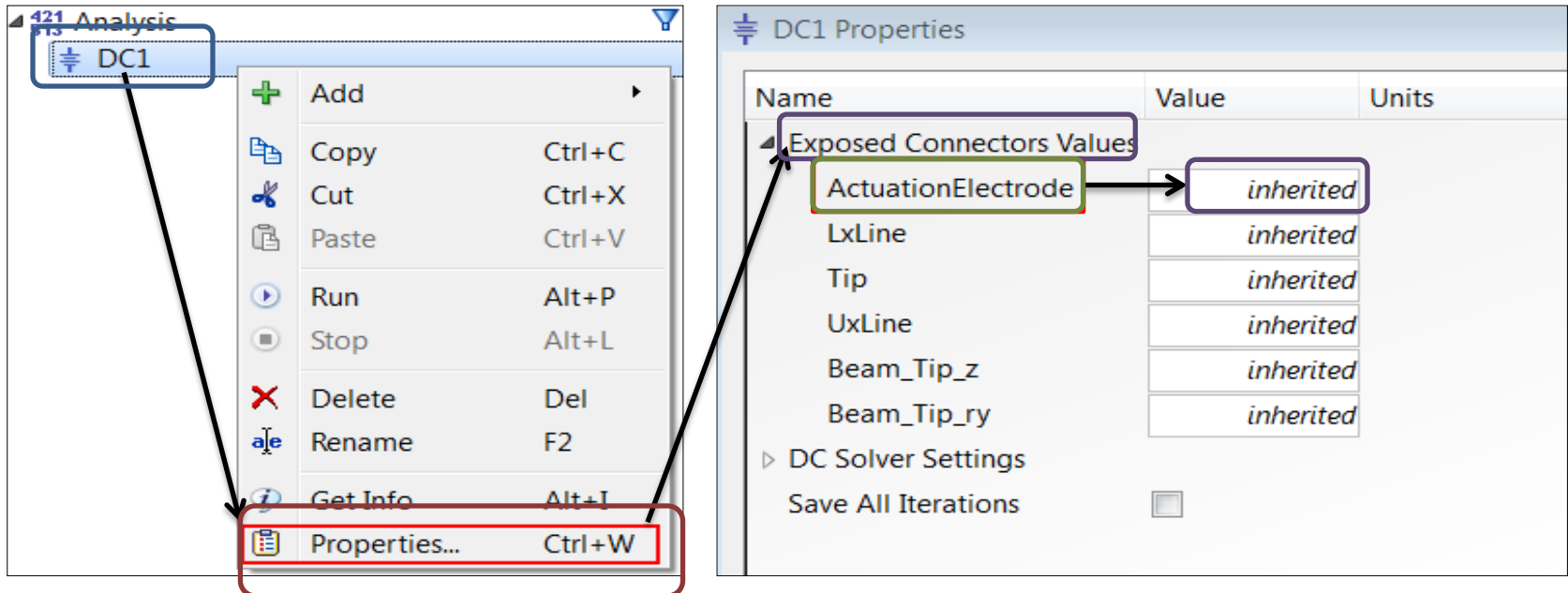

Corresponding Matlab construct

```

<DC_Analysis_Object>.Properties.ExposedConnectorsValues.
ActuationElectrode = <argument>
    
```

Built in Code Updater for upgrading the existing scripts

Enhanced ROM Export Simulink and Verilog-A

COVENTOR

Non-linearities are now captured *analytically* and not interpolated

- Electrical non-linearities
- Non-linear inertial forces
(Coriolis, Euler and centrifugal) **New!**
- Much simplified usage

ROMs include package effects

- Optionally, expose mechanical pins
as Force and/or Displacement
inputs in Verilog-A

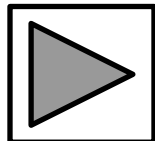

**Gyroscope
Demo**

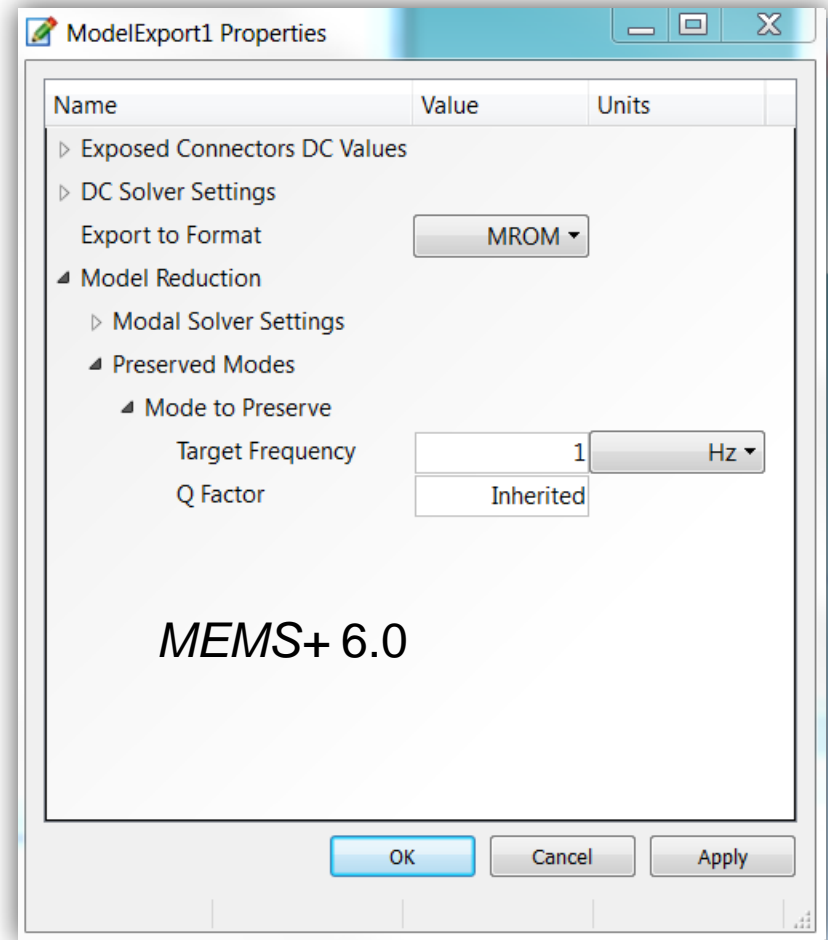

Murata 3-Axis Gyro Example

COVENTOR

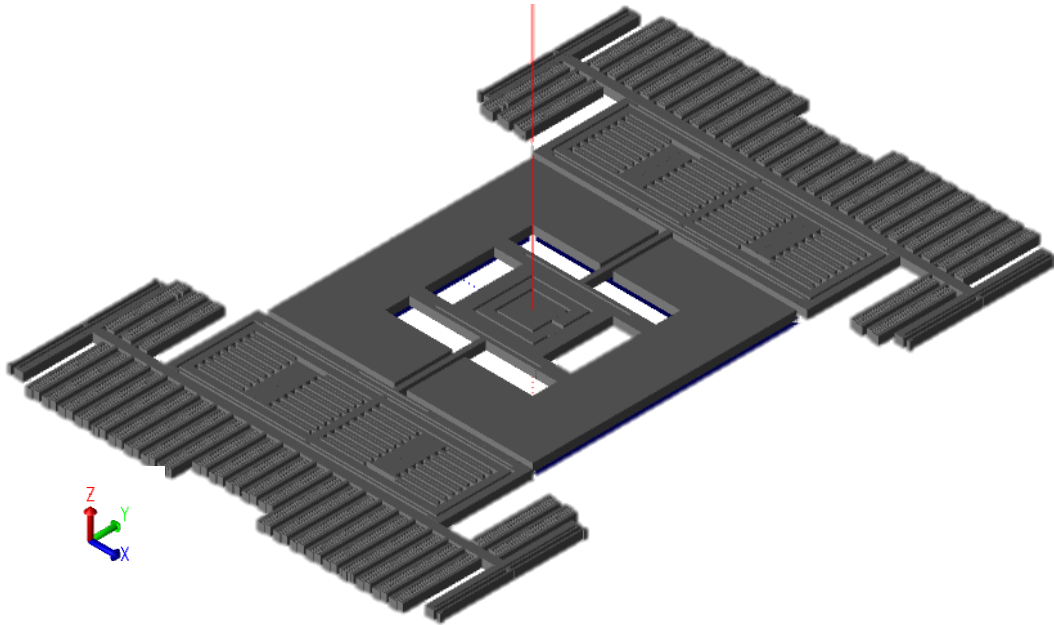

Efficient nonlinear Simulink model of MEMS gyroscopes generated with a novel model order reduction method, A. Parent *et al.* Transducers 2015.

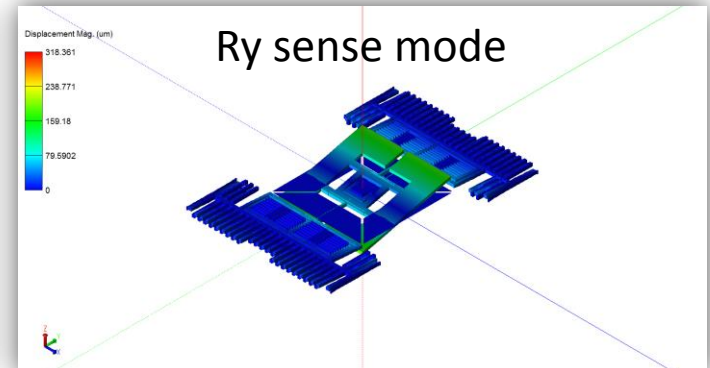
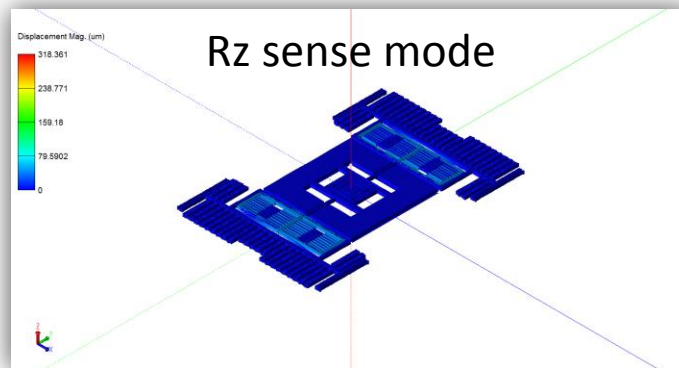
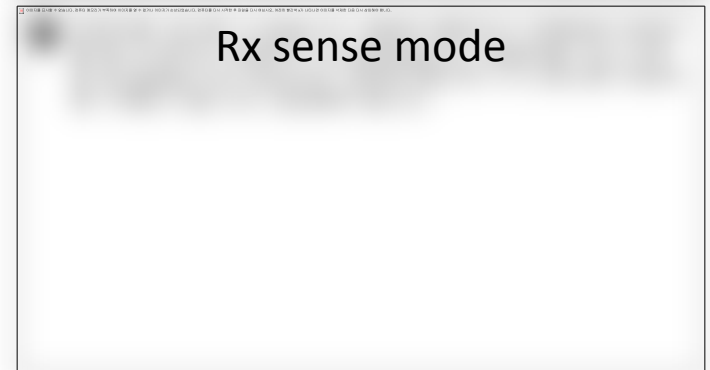
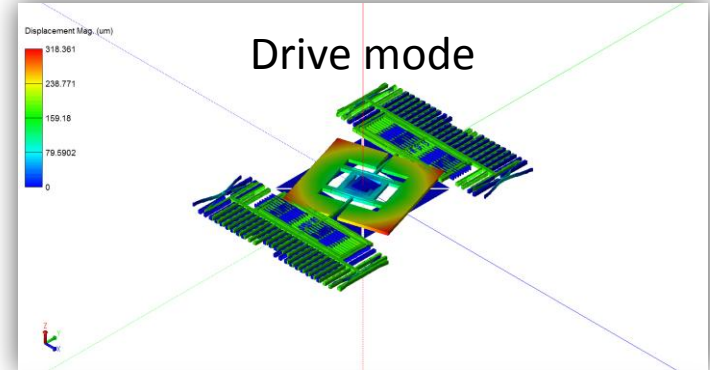

ROM Export and Simulation Setup

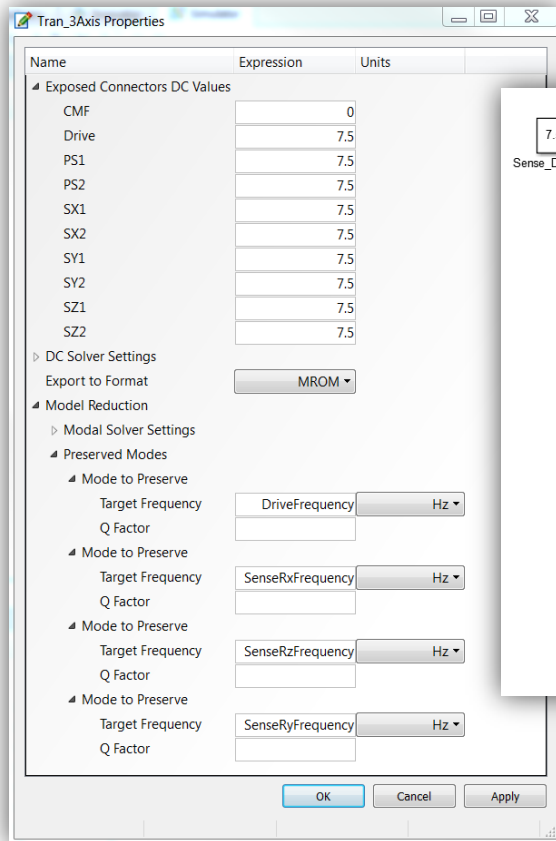

ROM Setup

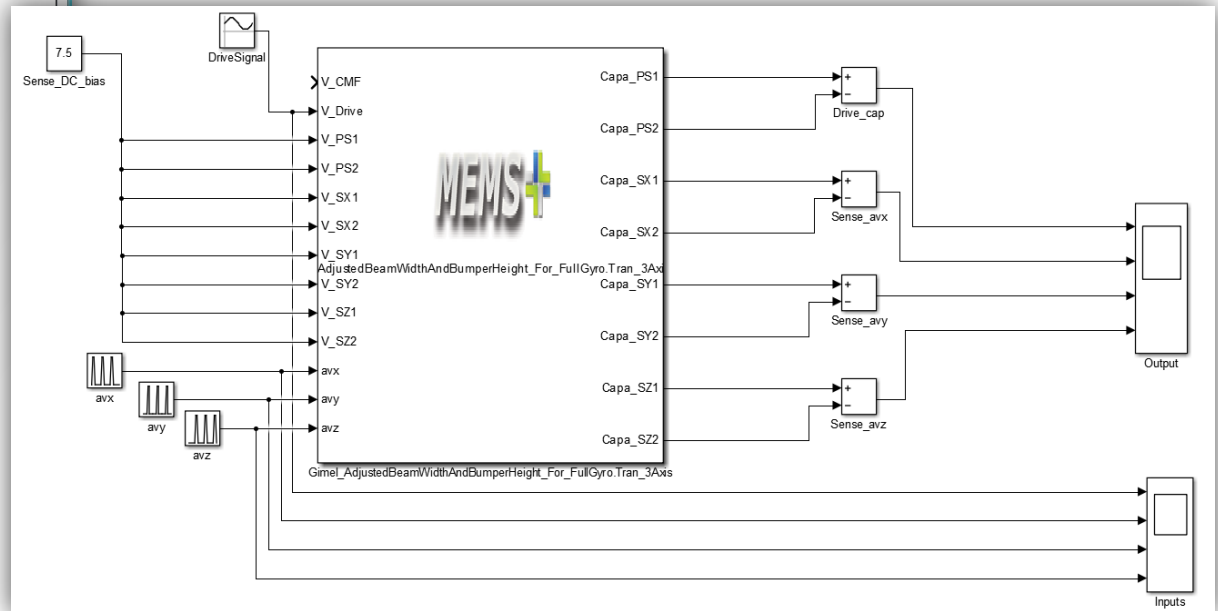

ROM in Simulink

Murata 3-Axis Gyro Example Real Time Transient Simulation

COVENTOR

Drive signal

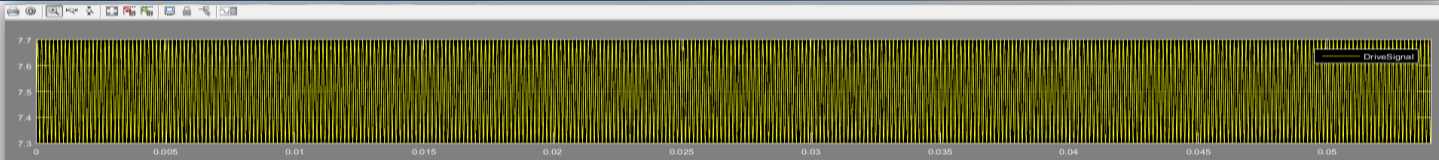

avx input

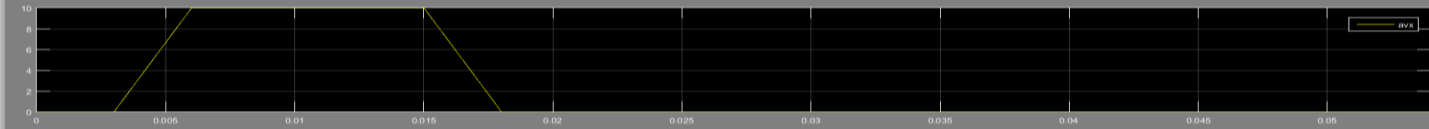

avy input



avz input

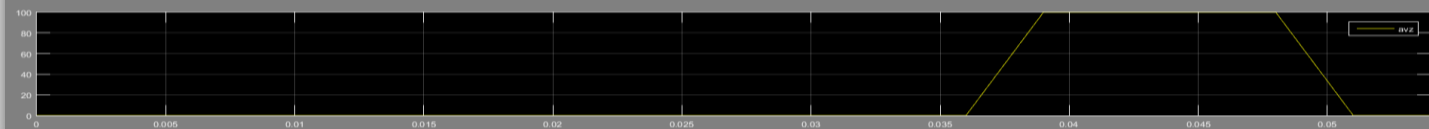

Drive capacitance



rx Sense signal



ry Sense signal

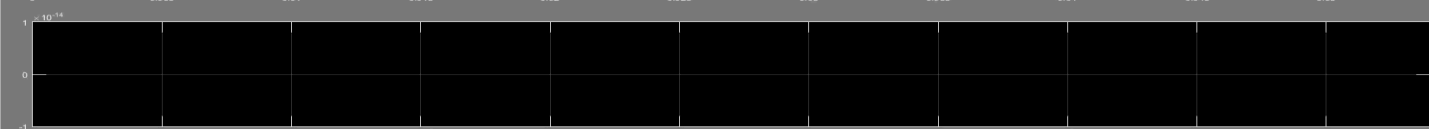

rz Sense signal



***MEMS+* 6.0 Beta now available**

- Expected release: Early October 2015
- Previous schematics and scripts will be auto-updated
- Supported OS (64-bit only) – Windows 7,8 and RHEL5, 6
- Matlab & Simulink version 2015a or higher required

Questions